

Special Foldingtools

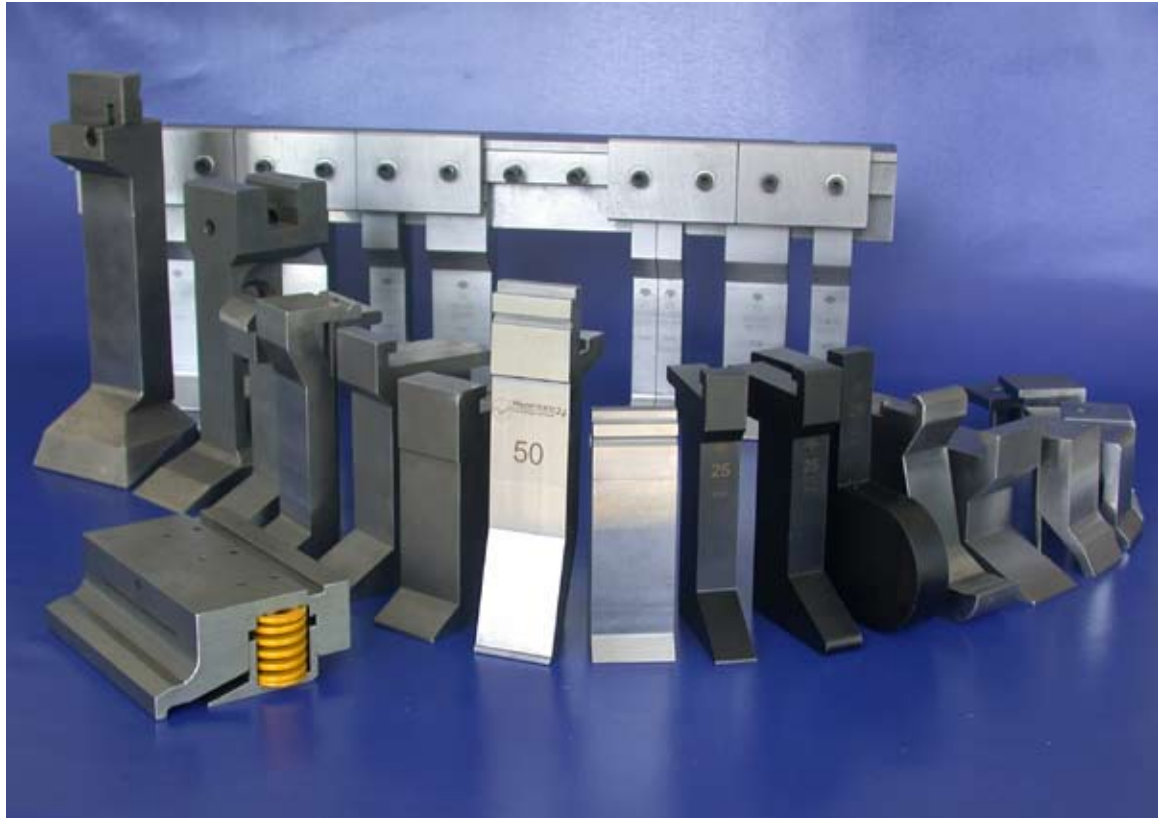

Upper tools for your folding machine...

Talas delivers special folding tools for your machine.
 You will get paint coated and grinded tools.
 According the order wearing stability Talas offers different quality levels
 determined orhardened.



... or conventional tools.



keystrokes tills 6500 mm



adaptor rail for divides tools

Special Foldingtools

directly able to work on folding machines of:

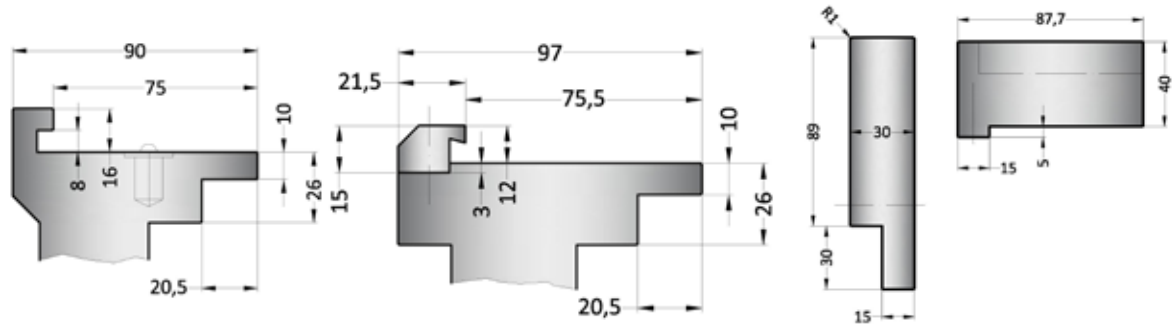

Fasti

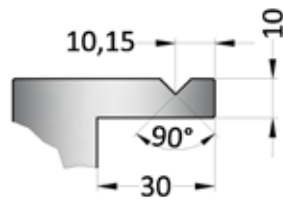

Schröder

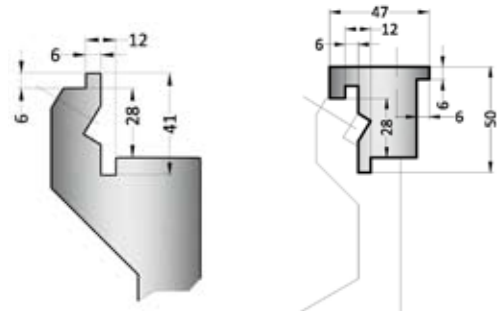

RAS

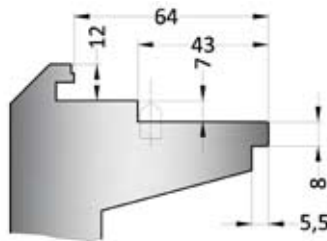

RAS

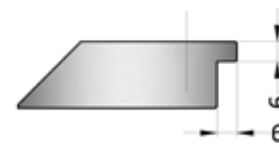

Lotze

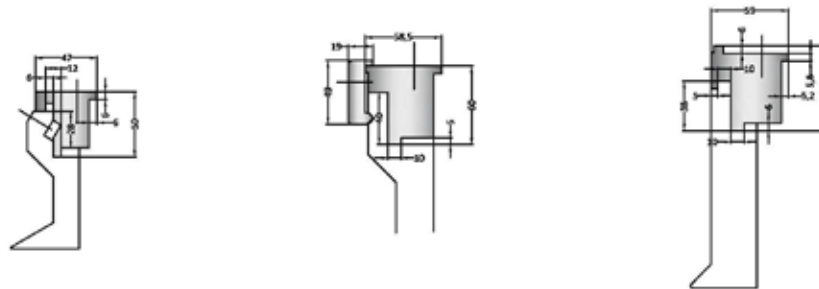

modified for your machine

material:

Talas uses the many possibilities of the material engineering, to guarantee best quality.

used materials are:

- 1.2312, tempered to 1000-1200N/mm²

Design optional:

Milled, grinded or additional hardened

4.01.001

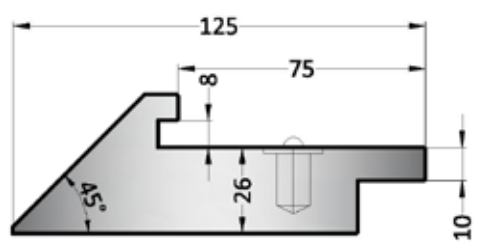

45°

4.01.002

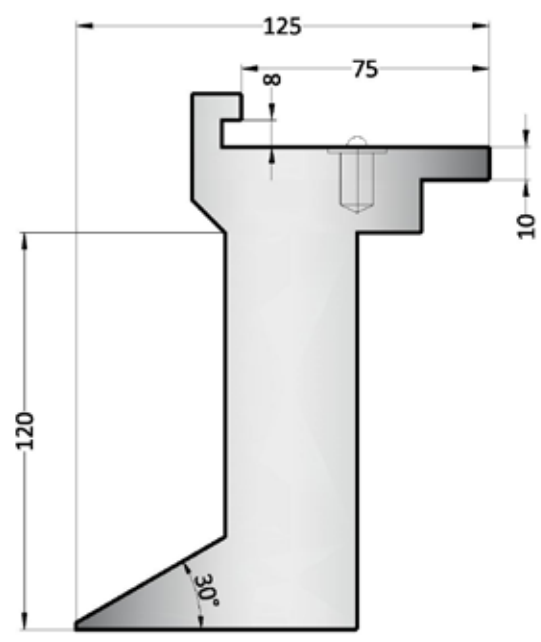

30°

4.01.003

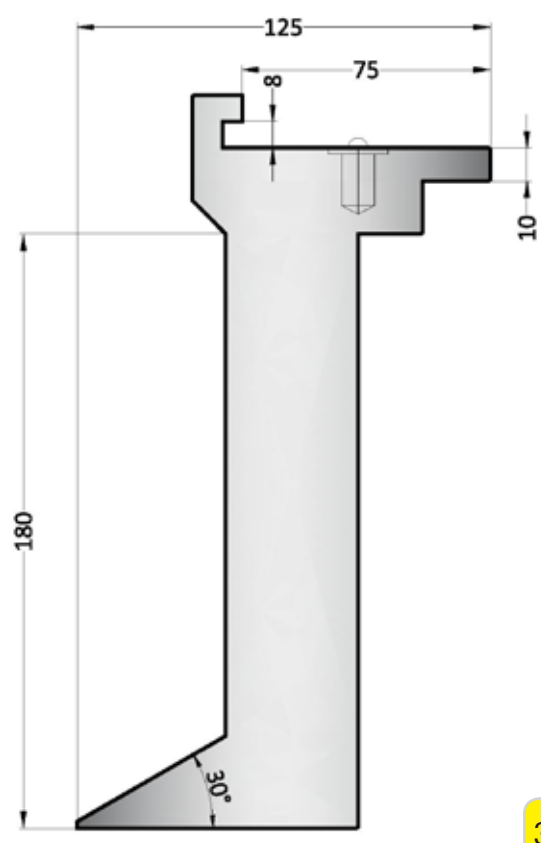

30°

4.01.004

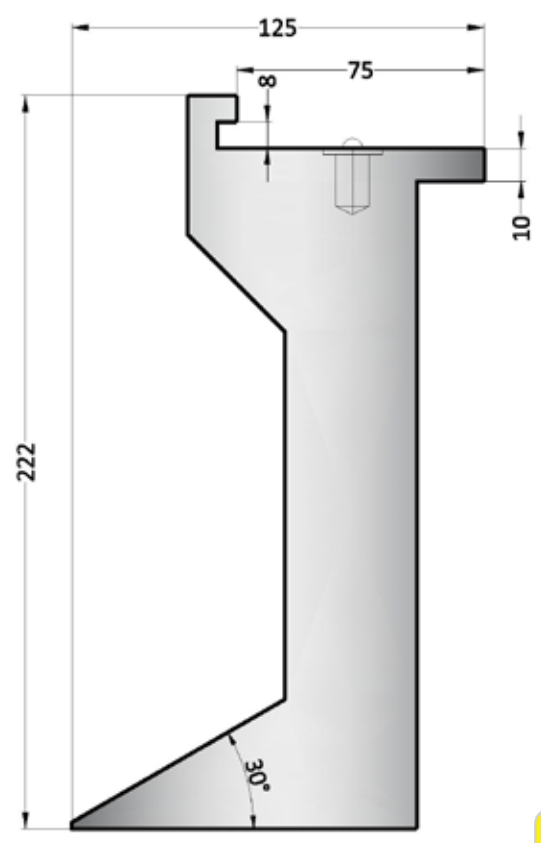

30°

4.01.005

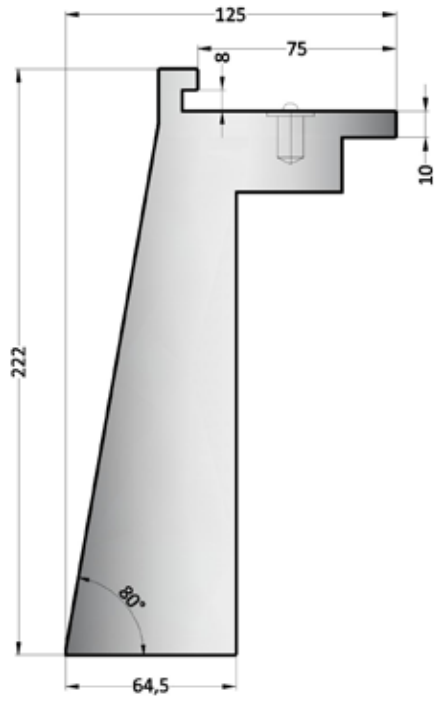

80°

4.01.006

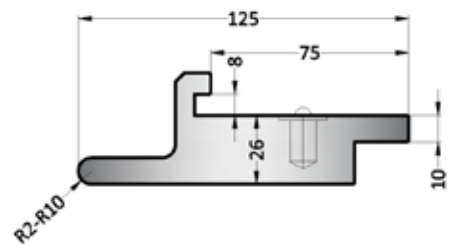

45°

4.02.001

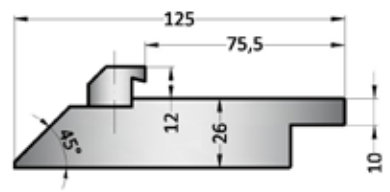

45°

4.01.007

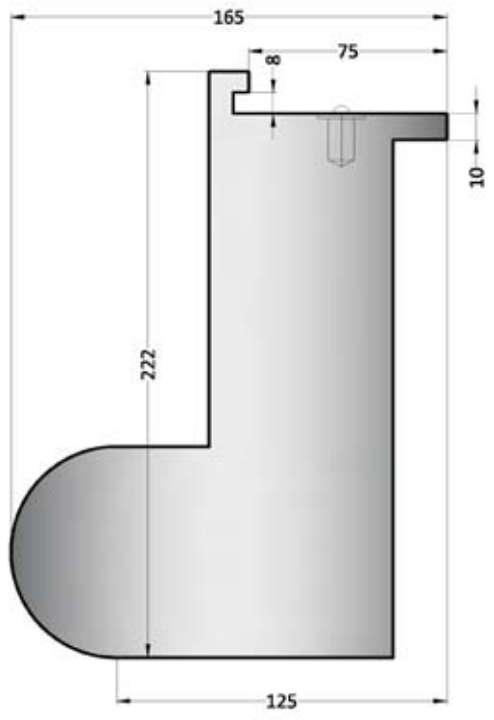

4.02.002

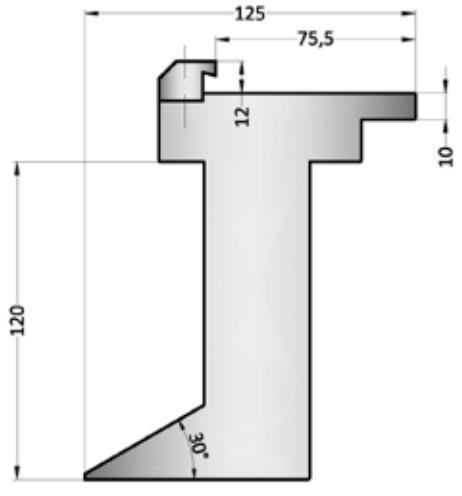

30°

4.02.003

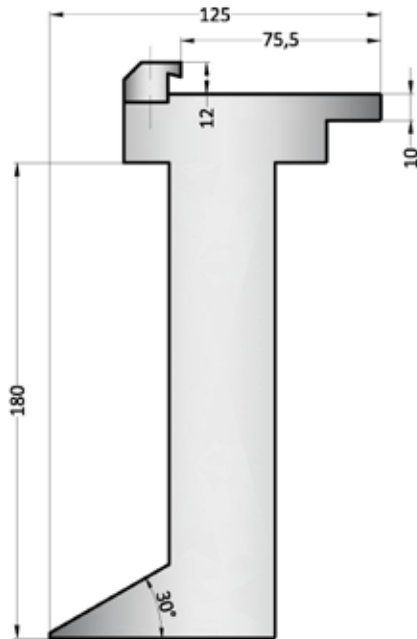

30°

4.02.004

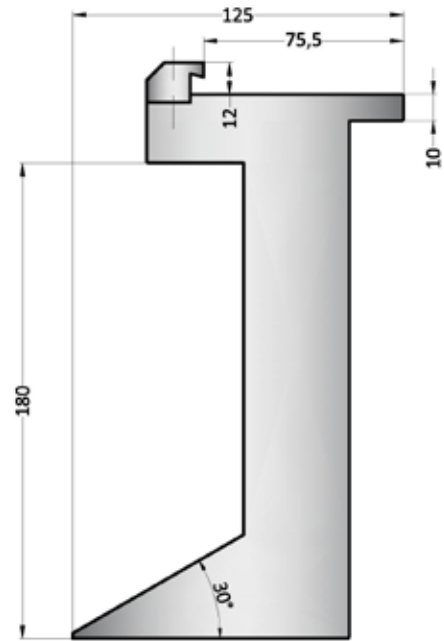

30°

4.02.005

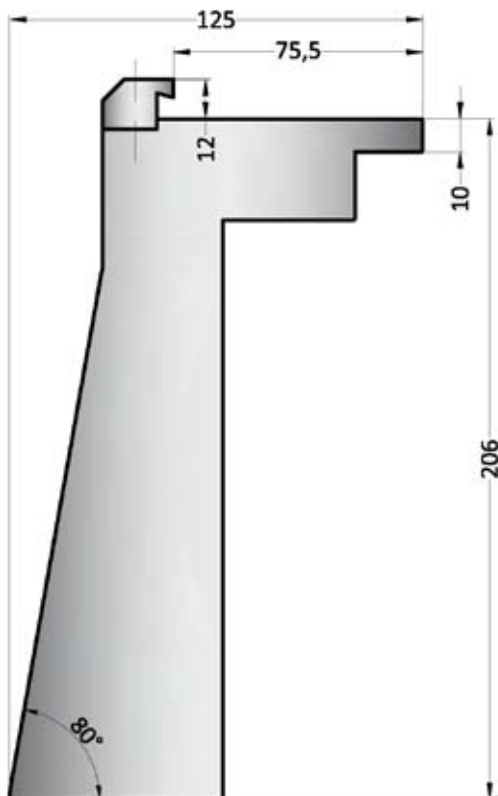

80°

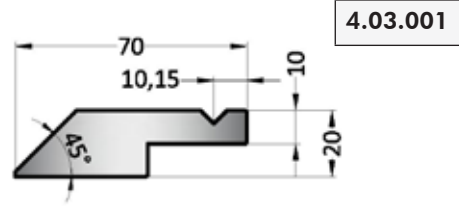
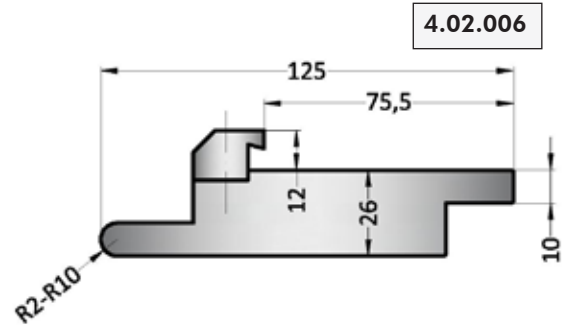
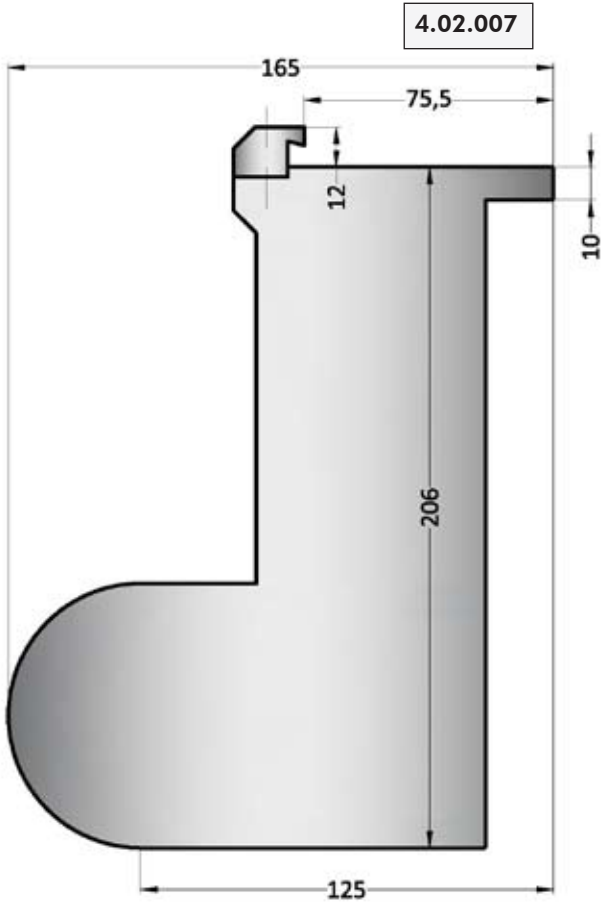

45°

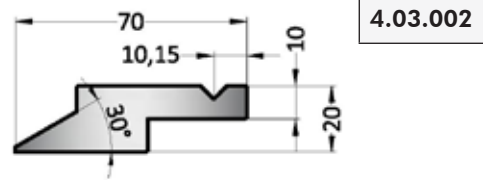

30°

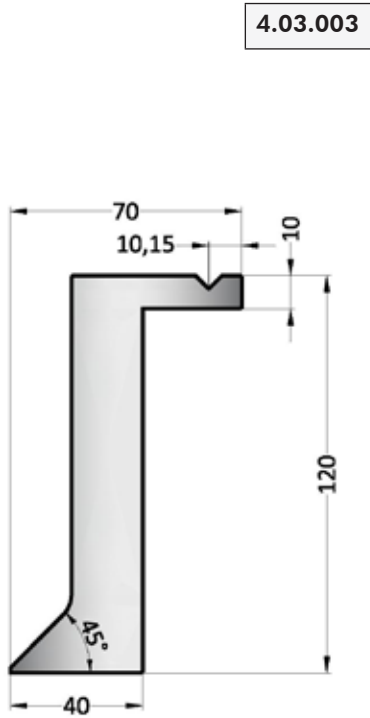

45°

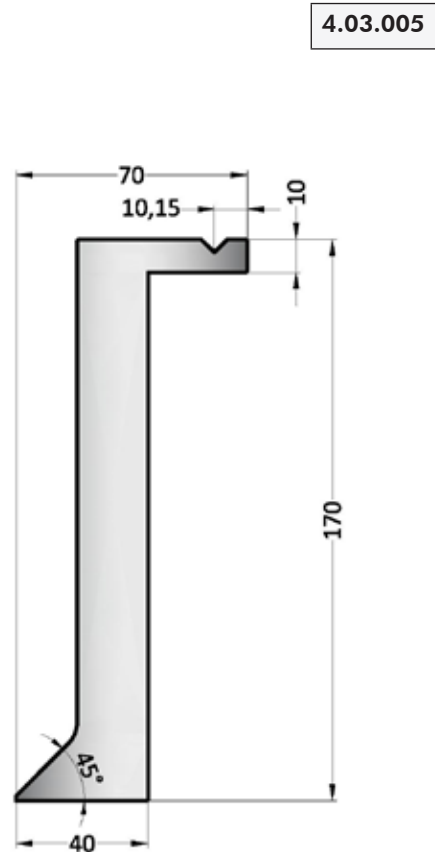

45°

4.03.006

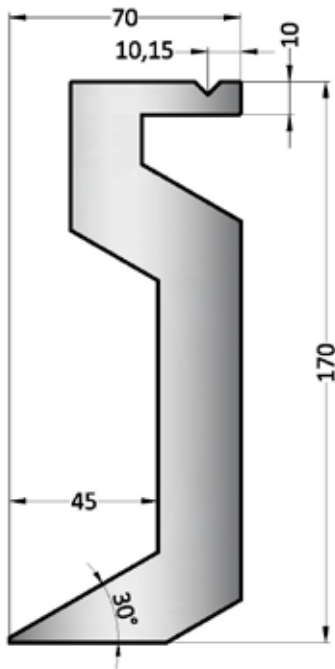

30°

4.03.007

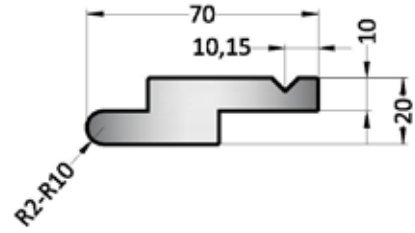

4.04.001

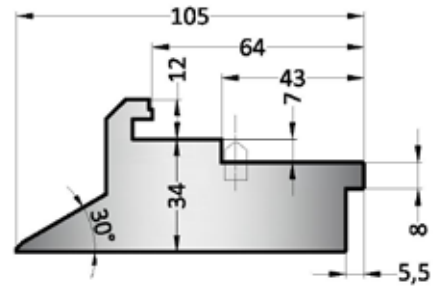

30°

4.03.008

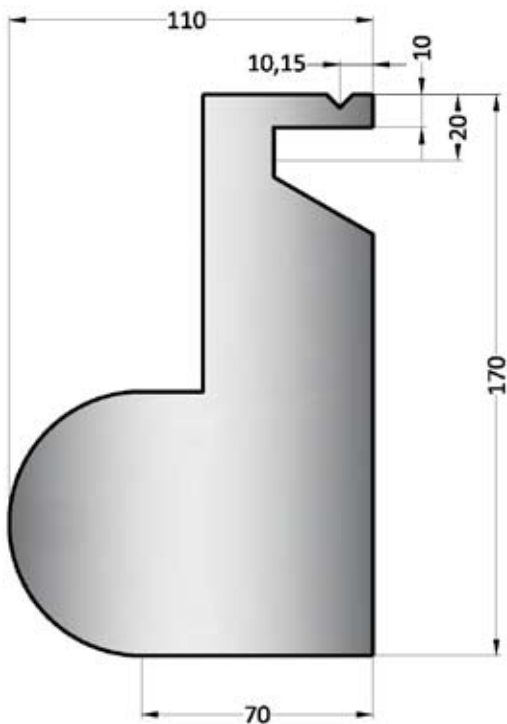

4.04.002

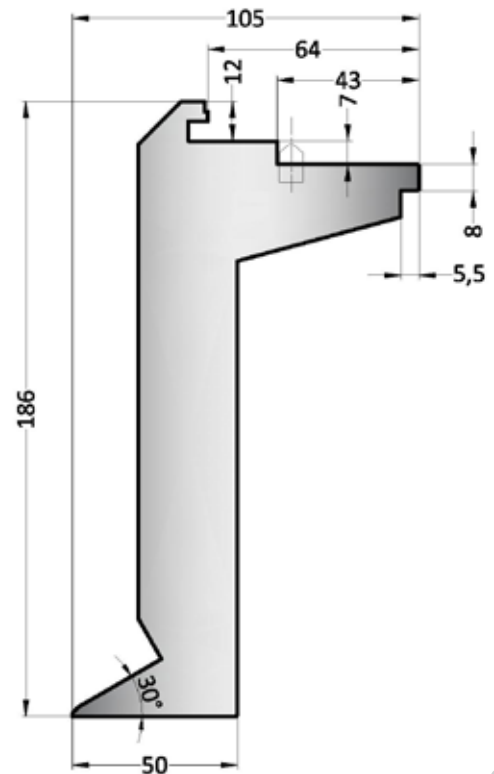

30°

4.04.003

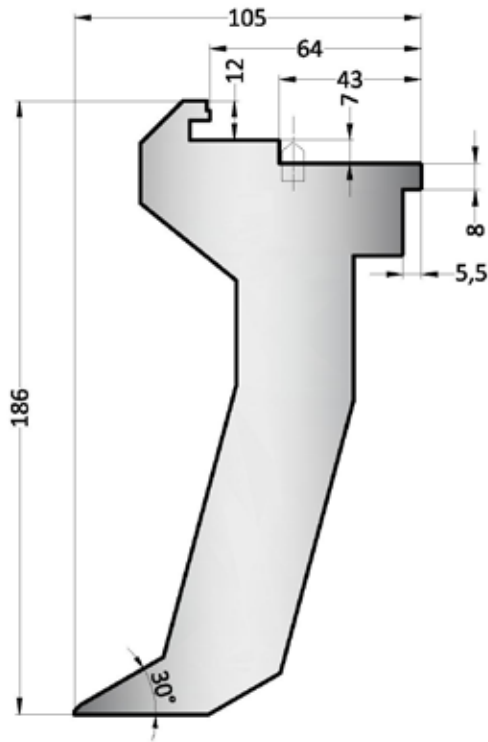

30°

4.04.004

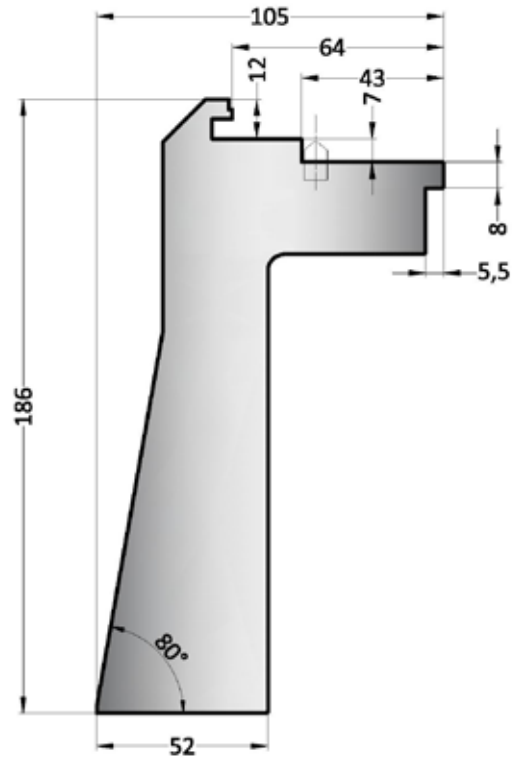

80°

4.04.005

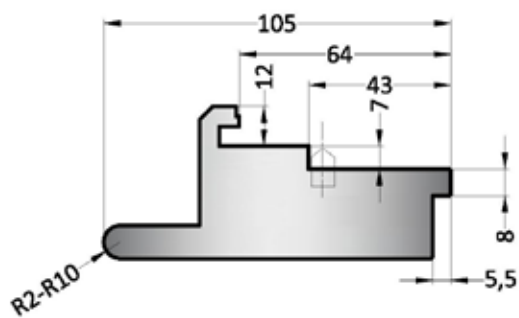

4.04.006

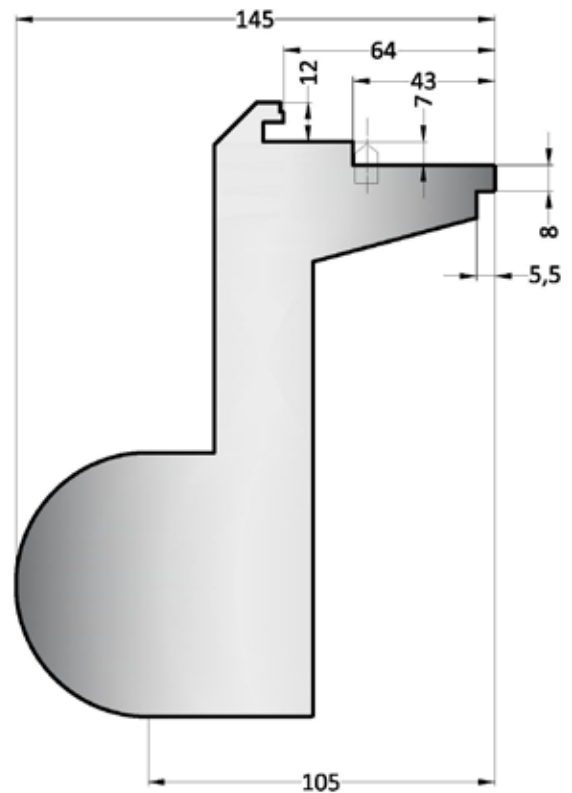

4.05.001



30°

4.05.002

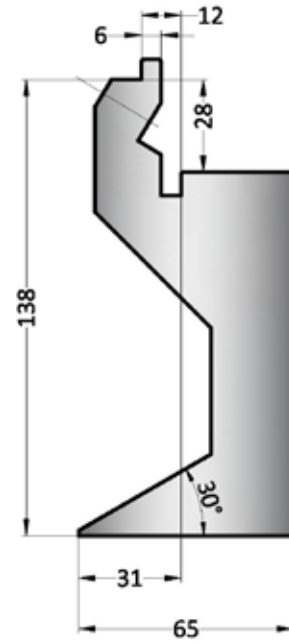

30°

4.05.003

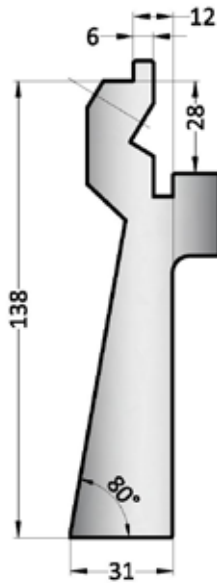

80°

4.05.004

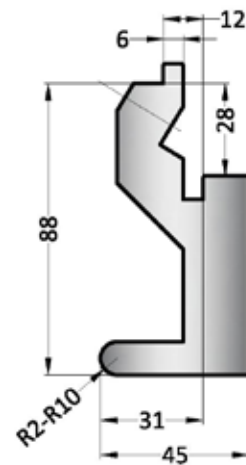

4.05.005

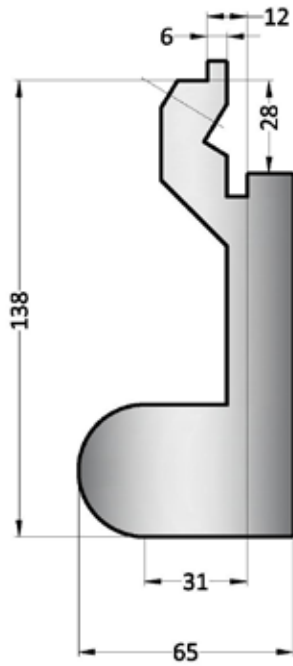

4.06.001

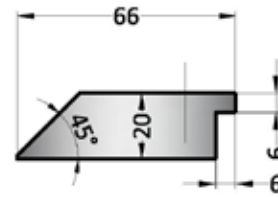

45°

4.07.001

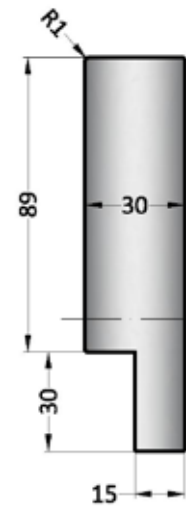

4.06.002

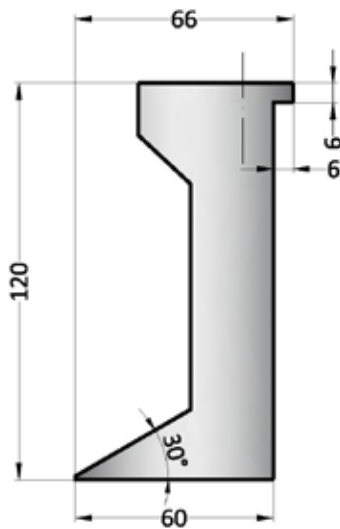

4.07.002

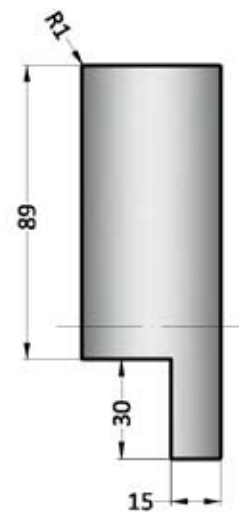

30°

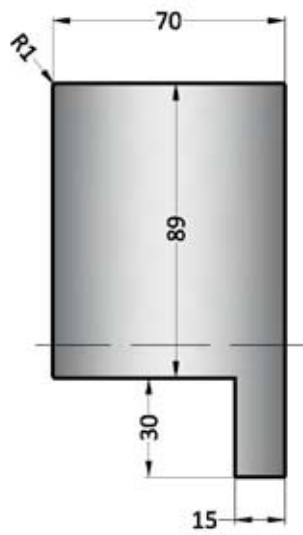

4.07.003

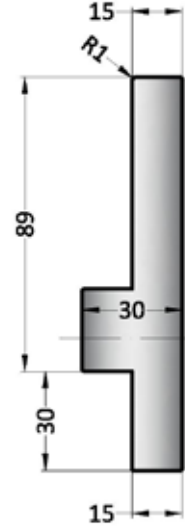

4.07.004

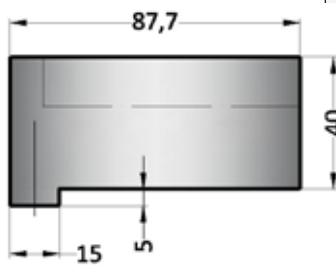

4.08.001

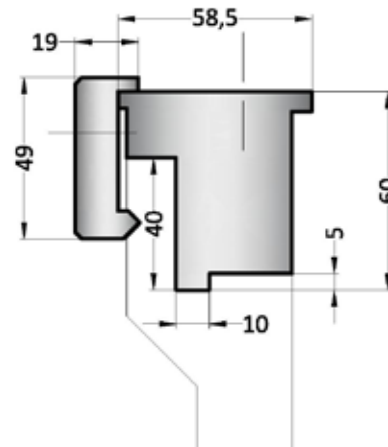

5.01.002

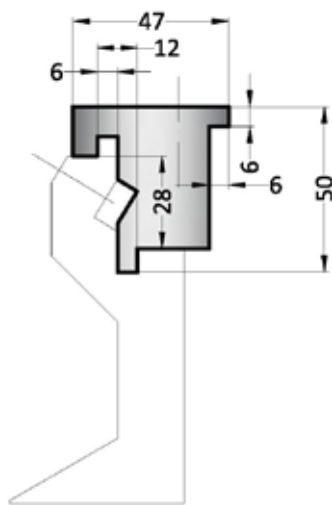

5.01.001

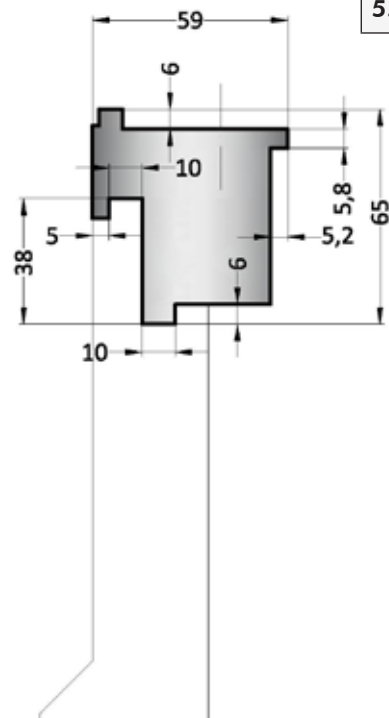

5.01.003